

Direct current dimmable electronic drivers with DIP-SWITCH
Alimentatori elettronici regolabili in corrente continua con DIP-SWITCH

Made in Europe

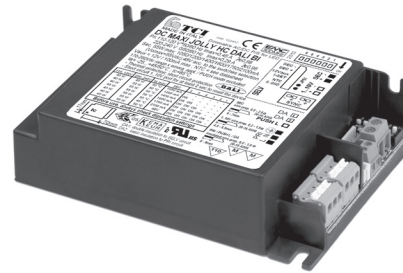

DC MAXI JOLLY HC/2 DALI



DC MAXI JOLLY HC DALI BI



Article Articolo	Code Codice	P out W	V out DC	I out DC	V out max.	ta °C	tc °C	λ max. Power Factor	η max. Efficiency ⁽¹⁾
DC MAXI JOLLY HC/2 DALI ⁽⁵⁾	123314 (ex. 127314)	45 (40 ⁽²⁾)	2...44	1,05 A cost.	55	-25... +45 ⁽⁵⁾ /50	80	0,95 ⁽³⁾	> 92
		52 (40 ⁽²⁾)	2...44	1,2 A cost.					
DC MAXI JOLLY HC DALI BI	123417 (ex. 122417 ex. 122303)	55 ⁽⁵⁾ /60 (40 ⁽²⁾)	2...43	1,4 A cost.					
		55 ⁽⁵⁾ /60 (40 ⁽²⁾)	2...38	1,6 A cost.					
		55 ⁽⁵⁾ /60 (40 ⁽²⁾)	2...35	1,75 A cost.					
		55 ⁽⁵⁾ /60 (40 ⁽²⁾)	2...29	2,1 A cost.					
48Vout voltage limit settable with Dip-Switch - Poutmax=55 ⁽⁵⁾ /60 W									

⁽¹⁾ Referred to $V_m = 230$ V, 100% load - Riferito a $V_m = 230$ V, carico 100%

⁽²⁾ Pout > 35W

$\lambda > 0,91$ for Pout > 25W

⁽³⁾ 123314BIS - 123417BIS:
[order codes for BIS marked product](#)
[codici di ordine per il prodotto marchiato BIS](#)

⁽⁴⁾ Only for DC MAXI JOLLY HC/2 DALI

Accessories not supplied - Accessori non a corredo

Article - Articolo	L (length)	Code - Codice
Synchronization cable Cavetto di sincronizzazione	1,5 m / 4 ft	485720512
	4 m / 13 ft	485720513
	50 cm / 19,68"	485720515
	20 cm / 7,87"	485720516
6-pin cable for LED and AUX Cavo 6 poli per LED e AUX	50 cm / 19,68"	425720017
REG 1-10 V (pag. 341)		123999L
BMU DMX INTERFACE (pag. 346)		122066
ZLL INTERFACE (11.)		-

Features

- Multipower driver supplied with dip-switch for the selection of the output current.
- IP20 independent driver, for indoor use (DC MAXI JOLLY HC/2 DALI).
- Class I protection against electric shock for direct or indirect contact (DC MAXI JOLLY HC/2 DALI).
- Driver for built-in use (DC MAXI JOLLY HC DALI BI).
- It can be used for lighting equipment in protection class I.
- Active Power Factor Corrector.
- Analogical input (NTC) for thermal sensor connection.
- Auxiliary output 12 V max. 100 mA.
- Current regulation ± 5 % including temperature variations.
- Input and output terminal blocks on the same side (wire cross-section up to 1,5 - 2,5 mm² / AWG15 - AWG13).
- Clamping screws on primary and secondary circuits for cables with diameter: min. 3 mm - max. 8 mm (DC MAXI JOLLY HC/2 DALI).
- Protections:
 - against overheating and short circuits;
 - against mains voltage spikes;
 - against overloads.
- Thermal protection = C.5.a.

Caratteristiche

- Alimentatore multipotenza fornito di dip-switch per la selezione della corrente in uscita.
- Alimentatore indipendente IP20, per uso interno (DC MAXI JOLLY HC/2 DALI).
- Protetto in classe I contro le scosse elettriche per contatti diretti e indiretti (DC MAXI JOLLY HC/2 DALI).
- Alimentatore da incorporare (DC MAXI JOLLY HC DALI BI).
- Utilizzabile per apparecchi di illuminazione in classe di protezione I.
- PFC attivo.
- Entrata analogica (NTC) per connessione sensore termico.
- Uscita ausiliare 12 V max. 100 mA.
- Corrente regolata ± 5 % incluse variazioni di temperatura.
- Morsetti di entrata e uscita sullo stesso lato (sezione cavo fino a 1,5 - 2,5 mm² / AWG15 - AWG13).
- Serracavo su primario e secondario per cavi di diametro: min. 3 mm - max. 8 mm (DC MAXI JOLLY HC/2 DALI).
- Protezioni:
 - termica e cortocircuito;
 - contro le extra-tensioni di rete;
 - contro i sovraccarichi.
- Protezione termica = C.5.a.

3.1.2

Dimmable multipower DIP-SWITCH drivers - Compact case - DALI
 Alimentatori multipotenza regolabili con DIP-SWITCH - Formato compatto - DALI

Rated Voltage
Tensione nominale
 110 ÷ 120 V⁽²⁾
 220 ÷ 240 V

Frequency
Frequenza
 50...60 Hz

AC Operation range
Tensione di utilizzo AC
 100 ÷ 264 V

DC Operation range
Tensione di utilizzo DC
 (see page info15)
 DC 170 ÷ 280 V
 (NO PUSH mode function)

Power
Potenza
 0 ÷ 60 W

Output current ripple
 $\leq 3\%$ ⁽¹⁾

Reference Norms
Norme di riferimento
 CSA-C22.2 n° 107.1⁽²⁾
 CSA-C22.2 n° 250.13 -14⁽²⁾
 EN 50172 (VDE 0108)
 EN 55015
 EN 60598-1
 EN 61000-3-2
 EN 61000-3-3
 EN 61347-1
 EN 61347-2-13
 EN 61547
 EN 62384
 EN 62386-101
 EN 62386-102
 EN 62386-207
 IS 15885 (Part 2/Sec 13)
 UL 1310⁽²⁾
 UL 8750⁽²⁾
 VDE 0710-T14

Max. pcs for CB B16A
 (see page info17)
 30 pcs

In rush current
 10A 200µsec



Direct current dimmable electronic drivers with DIP-SWITCH
Alimentatori elettronici regolabili in corrente continua con DIP-SWITCH

Made in Europe



IP 20



SCREW FIXING

Ø90
3,54"

Weight - Peso gr. 250 / 9 oz.
Pcs - Pezzi 40

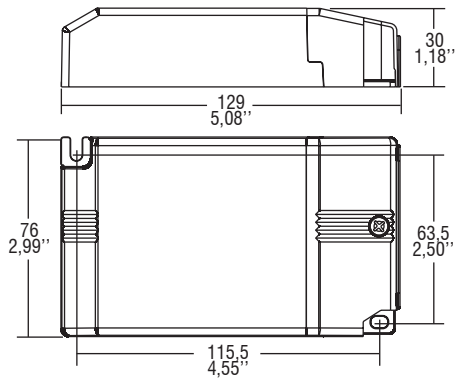

BUILT-IN



SCREW FIXING

Weight - Peso gr. 235 / 9 oz.
Pcs - Pezzi 40

Compatible with ZHAGA (AM2)

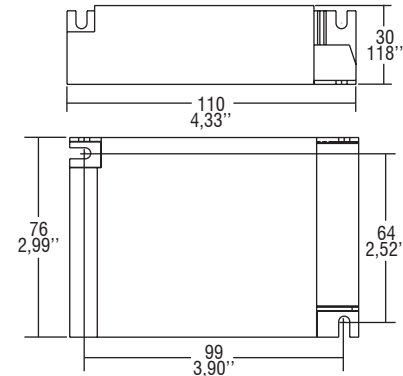

Wiring diagram - Schema di collegamento (Max. LED distance on page info8 - Massima distanza LED a pagina info8)

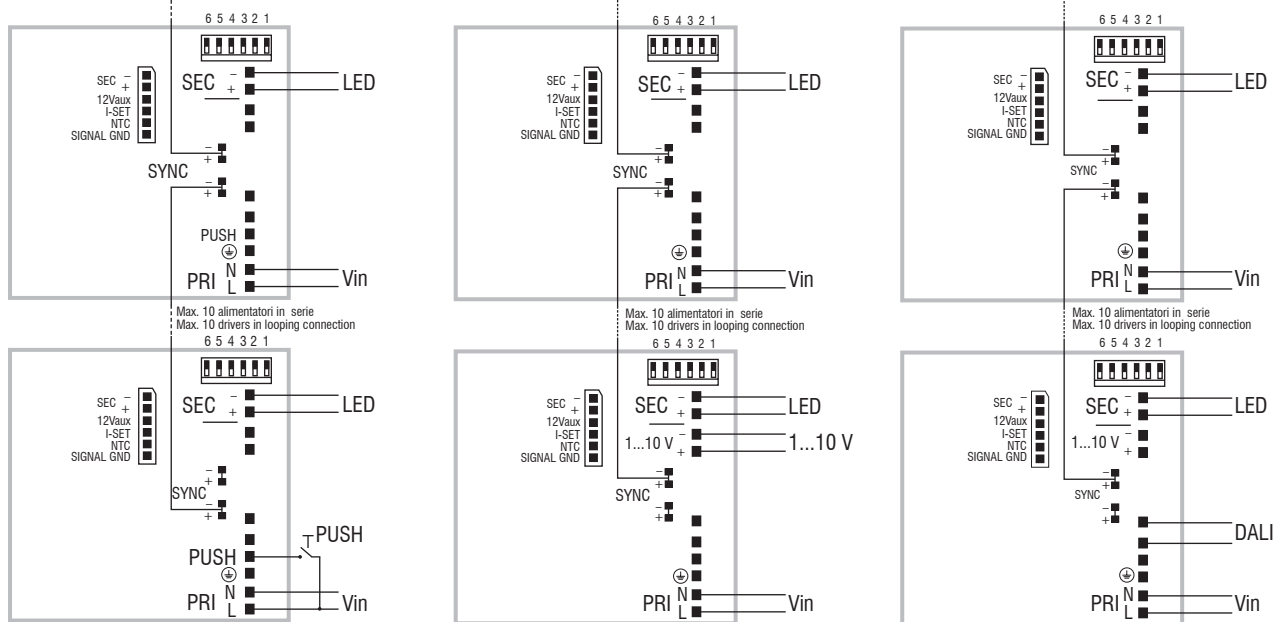

PUSH diagram - Collegamento PUSH

1...10 V diagram - Collegamento 1...10 V

DALI diagram - Collegamento DALI

Operation Mode

- Light regulation 0/0,5 - 100 % by means of PUSH function, 1...10 V interface ($I=1$ mA) or 100 Kohm potentiometer and DALI.
 - Features DALI dimming:
 - memory function for sets or light groups;
 - recall of stored functions;
 - compatible with standard DALI interfaces.
 - Light regulation 0/0,5 - 100 % by means of PUSH function (mains voltage):
 - a short push to turn on and off;
 - a longer push to increase or decrease light intensity;
 - regulation automatically stops at minimum and maximum values;
 - for another on, regulation or off command, release the push button and give the desired command again.
 - **dimming level memory at mains restore.**
 - Possibility to use PUSH function to 4/5 drivers without sync cable.
 - Maximum length of the cable, from push button to last driver, must be max. 15 m / 49 ft. In case of applications where the cable is longer than 15 m / 49 ft, keep this separate from the 110 - 240 Volt mains cable.
 - ATTENTION: only use normally open push buttons with no incorporated warning light.
 - Specific dimming terminal connection with a 1...10 Vdc electronic potentiometer (1...10 V local dimming, double insulation required for external connection).
 - Max. 10 synchronised drivers of which only one can be controlled (1 Master + 9 Slaves).
 - Synchronization cable is separately supplied.
- For additional details for regulations see pages info12-14.

Modalità di funzionamento

- Regolazione della luminosità 0/0,5 - 100 % mediante funzione PUSH, interfaccia 1...10 V ($I=1$ mA) o potenziometro da 100 Kohm e DALI.
 - Caratteristiche della regolazione DALI:
 - funzione di memoria per scenari o gruppi luminosi;
 - richiamo di funzioni memorizzate;
 - compatibilità con interfacce DALI standard.
 - Regolazione della luminosità 0/0,5 - 100 % mediante la funzione PUSH (tensione di rete):
 - una pressione breve per accendere e spegnere;
 - una pressione prolungata per aumentare o diminuire l'intensità luminosa;
 - la regolazione si ferma automaticamente ai valori minimi e massimi;
 - per un nuovo comando accensione, regolazione o spegnimento, rilasciare il pulsante e dare nuovamente il comando desiderato.
 - **ripristino del livello di dimming al ritorno alimentazione.**
 - Possibilità di utilizzo funzione PUSH fino a 4/5 alimentatori senza cavo di sincronismo.
 - La lunghezza massima del cavo, dal pulsante all'ultimo trasformatore, deve essere max. 15 m / 49 ft. In caso di applicazioni dove il cavo superi i 15 m / 49 ft, tenere lo stesso separato dal cavo di rete 110 - 240 Volt.
 - ATTENZIONE: usare solo pulsanti di tipo normalmente aperto privi di spia luminosa incorporata.
 - Provvisto di morsetto specifico per la regolazione collegando un potenziometro elettronico 1...10 Vdc (dimmerazione locale 1...10 V, per connessioni esterne all'apparecchio garantire il doppio isolamento).
 - Max. 10 alimentatori sincronizzati, di cui uno solo comandato da uno o più punti (1 Master + 9 Slaves).
 - Cavetto per la sincronizzazione fornito separatamente.
- Per ulteriori dettagli sulle regolazioni vedi pagine info12-14.

3.1.2

Dimmable multipower DIP-SWITCH drivers - Compact case - DALI
Alimentatori multipotenza regolabili con DIP-SWITCH - Formato compatto - DALI