

DALI 2Ch LED Dimmer

Datasheet Control Gear



2-Channel LED Dimmer (CV)

Art. Nr. 89453827 (4A)

Art. Nr. 89453833 (8A)

Art. Nr. 86459561 (10A)

Art. Nr. 89453830 (16A)

Art. Nr. 89453830-HS (16A, Dinrail)

DALI 2Ch LED Dimmer Control Gear

Overview

- 2 Channel LED Dimmer
- Suitable for constant voltage LED-modules
- Enables separate control of 2 PWM-outputs via DALI
- Each channel has got an own DALI-address
- The output is dimmable from 1% to 100% (upon request 0.1%)
- Supply voltage from 12V to 28V DC or 12V to 48V DC dependent on type
- Configuration via DALI-Cockpit software and DALI USB interface
- 4 types of housing
- Depending on product-type the maximum input current must not exceed 4A, 8A, 10A or 16A.
- The input current can be distributed at will on the channels

Specification, Characteristics

type	DALI 2Ch LED Dimmer				
article number	89453827	89453833	86459561	89453830	89453830-HS
Electical data:					
supply voltage	12VDC-28VDC		12VDC-48VDC		
maximum input current	4A	8A	10A	16A	
maximum output current per channel	4A	8A	10A	16A	
control input	DALI				
typ. current consumption DALI	2mA				
number of DALI addresses	2				
default state after power return	configurable				
Mechanical data:					
ambient temperature	-20°C bis +50°C		-20°C bis +60°C		-20°C bis +55°C
protection class	IP20				
max. connecting wire cross section	1.5 mm ²		2.5 mm ²		
geometry (L x W x H)	40 x 28 x 14 mm	59 x 33 x 15 mm	120 x 30 x 21mm		90 x 56 x 17 mm

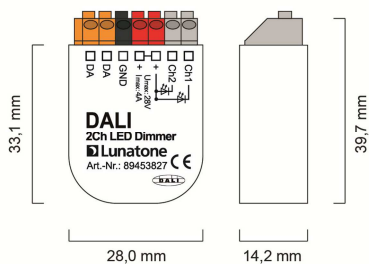

geometry 4A



connection plan 4A

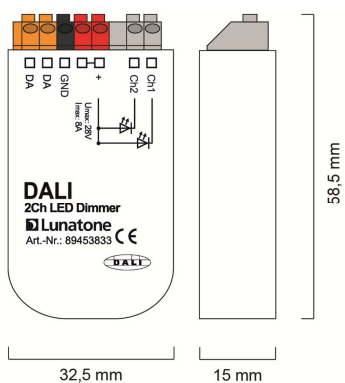

geometry 8A

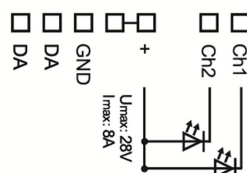

connection plan 8A

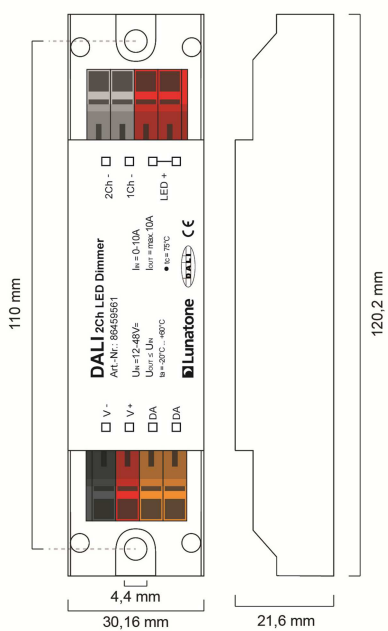

geometry 10A and 16A (remote ceiling)

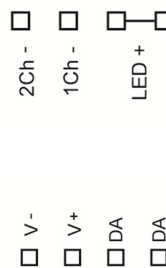

connection plan 10A und 16A (remote ceiling)

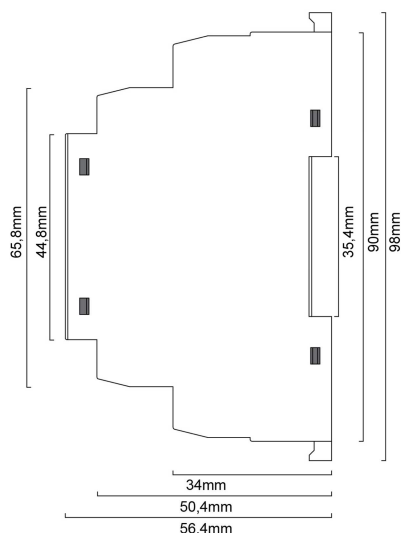

geometry 16A DinRail



connection plan 16A DinRail

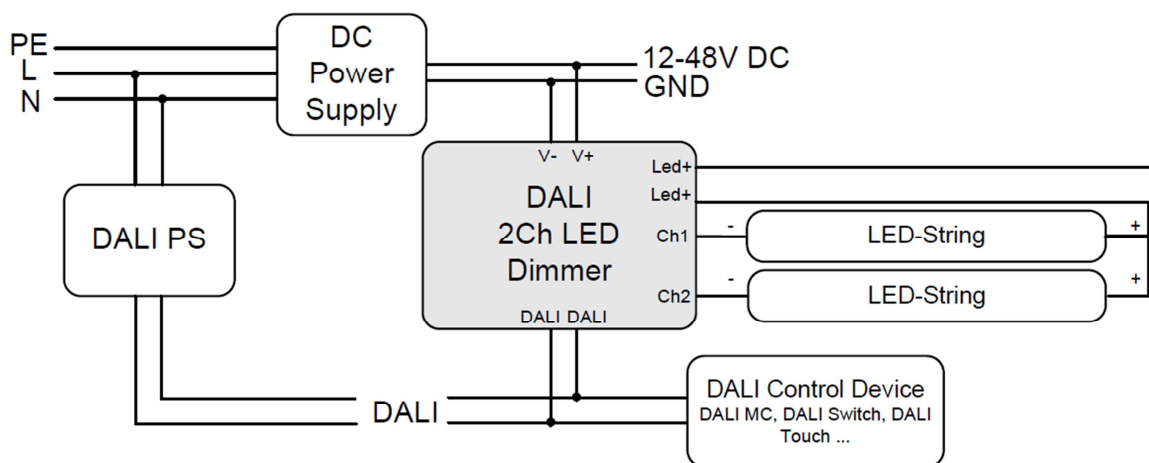

typical application

RECOMMENDATION: Care should be taken on keeping cable lengths between DC power supply and dimmer as well as between dimmer and luminaires (Led-Strings) as short as possible. This kind of installation will minimize the influence of voltage drops.

Purchase Information

ArtNr. 89453827: 2-Channel LED Dimmer, CV, max. input current 4A, 12V-28V DC, back box

ArtNr. 89453833: 2-Channel LED Dimmer, CV, max. input current 8A, 12V-28V DC, back box

ArtNr. 86459561: 2-Channel LED Dimmer, CV, max. input current 10A, 12V-48V DC, remote ceiling & built in

ArtNr. 89453830: 2-Channel LED Dimmer, CV, max. input current 16A, 12V-48V DC, remote ceiling & built in

ArtNr. 89453830-HS: 2-Kanal LED Dimmer, CV, A max. input current 16A, 12V-48V DC, din rail

Additional Information and Equipment

DALI-Cockpit – free configuration tool from Lunatone for DALI systems

<http://lunatone.at/en/downloads/Lunatone-DALI-Cockpit.zip>

Lunatone DALI products

<http://www.lunatone.at/en/>

Lunatone datasheets and manuals

<http://lunatone.at/en/downloads/>

Contact

Technical Support: support@lunatone.com

Requests: sales@lunatone.com

www.lunatone.com



Disclaimer

Subject to change. Information provided without guarantee.
The datasheet refers to the current delivery.

The function in installations with other devices must be tested for compatibility in advance.